

# LOW COST LINE MATCHING TRANSFORMER P3189

## Features

- \* Low Cost
- \* 12.6mm (0.5") seated height
- \* Industry Standard Pinout
- \* IEC 950, UL 1950 and EN 60950 Certified
- \* UL Recognized Component
- \* BAPT Certificate of Recognition
- \* High thermal stability

## Applications

- \* Telecommunications
- \* Voice
- \* Least-cost routers
- \* V.22bis

## DESCRIPTION

P3189 is designed as a lower cost replacement for industry standard P1200 and P3800 in applications where some relaxation of transformer signal distortion performance can be tolerated.

P3189 characteristics are tailored to provide a complete pin-for-pin replacement for existing P1200 and P3800 matching circuits, whilst providing good fidelity of voice and tone signals, typically <0.1% distortion at powers up to -6dBm, thus also suitable for low speed modems, e.g. V.22bis.

P3189 uses patented design and construction methods to achieve excellent signal performance and safety isolation to international standards at truly low cost. P3189 is certified to EN 60950, IEC 950, UL1950 and EN 41003. P3189 is a UL Recognized Component and is supported by a BAPT Certificate of Recognition and an IEC CB Test Certificate.

Patented



to Electronic Techniques  
(Anglia) Limited

## SPECIFICATIONS

### Electrical

At T = 25°C and as circuit fig. 2 unless otherwise stated.

Parameter	Conditions	Min	Typ	Max	Units
Insertion Loss	f = 2kHz, R <sub>L</sub> = 560Ω	-	-	1.5	dB
Frequency response	200Hz - 4kHz	-	-	±0.2	dB
Return Loss	200Hz - 4kHz	18	-	-	dB
Third Harmonic Distortion <sup>(1)</sup>	300Hz - 6dBm	-	-	-62	dBm
	697Hz - 6dBm	-	-	-70	dBm
Voltage isolation <sup>(2)</sup>	50Hz	2.12	-	-	kVrms
	DC	3.0	-	-	kV
Operating range: Functional Storage	Ambient temperature	0	-	+70	°C
		-40	-	+85	°C

Lumped equivalent circuit parameters as Fig. 1

DC resistance, R <sub>DC</sub> <sup>(3)</sup>	Sum of windings	124	-	152	Ω
Leakage inductance ΔL		14.5	-	18	mH
Shunt inductance L <sub>p</sub> <sup>(4)</sup>	-43dBm 200Hz	1.4	-	-	H
Shunt loss R <sub>p</sub> <sup>(4)</sup>	-43dBm 200Hz	4	-	-	kΩ

### Notes

1. Third harmonic typically exceeds other harmonics by 20dB.
2. Components are 100% tested at 3.25kV DC.
3. Caution: do not pass DC through windings. Telephone line current, etc. must be diverted using choke or semiconductor line hold circuit.
4. At signal levels greater than -20dBm, L<sub>p</sub> will increase and R<sub>p</sub> will decrease slightly but the effect is usually favourable to the return loss characteristic.

### Equivalent Circuit

Fig. 1

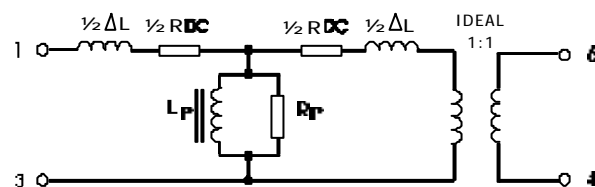

Patented

## MATCHING RECOMMENDATIONS

### 600Ω MATCH

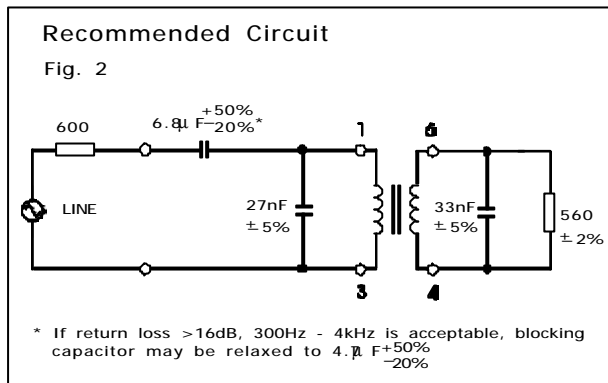
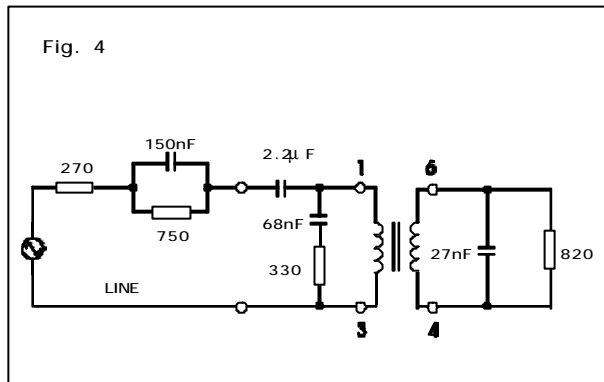
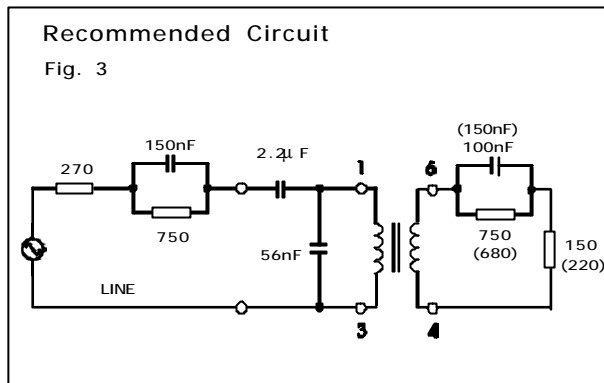

Figure 3 gives flat RX and TX responses against the CTR21 complex reference impedance (typically around  $\pm 0.5$ dB 300Hz - 3.4kHz). Return loss is typically better than 20dB. The circuit values in parentheses give optimum flatness at a small sacrifice in return loss.

For circuits with existing board drillings, figure 4 gives good return loss (>20dB) and RX flatness against the CTR21 complex reference impedance, but TX flatness is degraded by the use of this topology.

### EUROPEAN CTR21 COMPLEX MATCH



## CONSTRUCTION

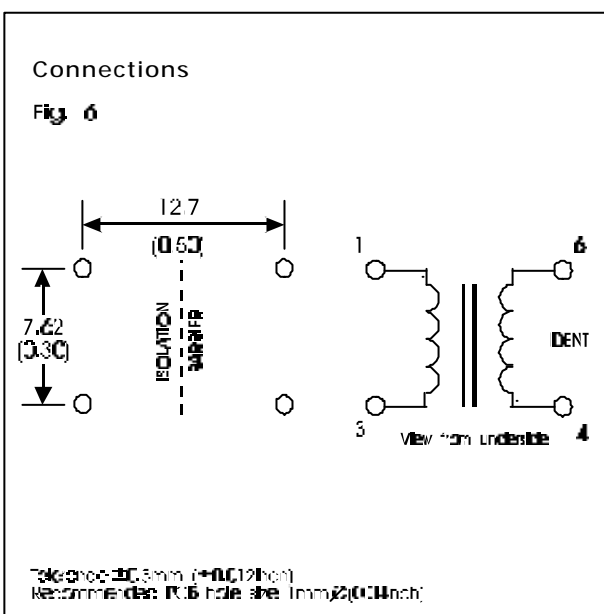
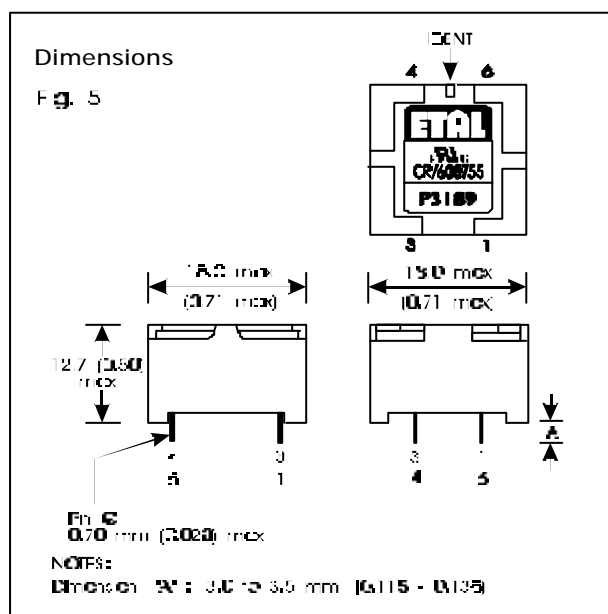

Dimensions shown are in millimetres (inches).

Geometric centres of outline and pin grid coincide within a tolerance circle of 0.6mm

Windings may be used interchangeably as primary or secondary.

**SAFETY**

Constructed in accordance with IEC 950:1991, EN60950:1992 (BS7002:1992), supplementary insulation, 250Vrms maximum working voltage, flammability class V-0.

There are no special installation requirements (beyond attending to usual PCB track separations) since the integral cover provides supplementary insulation from its external faces to internal core and windings.

**CERTIFICATION**

Certified under the IEC CB scheme (Certificate GB445W) to IEC 950:1991, up to amendment 4, sub-clauses 1.5, 1.5.1, 1.5.3, 2.2, 2.2.3, 2.2.4, 2.9.2, 2.9.3, 2.9.4, 4.4, 4.4.3.2 (class V-0) and 5.3 for a maximum working voltage of 250Vrms, nominal mains supply voltage not exceeding 300Vrms and a maximum operating temperature of 70°C in Pollution Degree 2 environments.

Recognized under the Component Recognition Program of Underwriters Laboratories Inc. to US and Canadian requirements CAN/CSA C22.2 No. 950-95/UL1950, Third Edition, including revisions through to revision date March 1, 1998, based on Fourth Amendment of IEC 950, Second Edition, maximum working voltage 250Vrms, Pollution Degree 2, supplementary insulation.

UL File number E203175.  
Approved and certified by BABT to EN 60950 and EN 41003.  
BABT Certificate of Recognition 608755

Additionally, Profec Technologies certifies all transformers as providing voltage isolation of 2.12kVrms, 3kV DC minimum. All shipments are supported by a certificate of conformity to current applicable safety standards.

**ABSOLUTE MAXIMUM RATINGS**

(Ratings of components independent of circuit).

Short term isolation voltage (1s)	2.12kVrms 3.0kVDC
DC current	100µA
Storage temperature	-40°C to +85°C
Lead temperature, 10s	260°C

**COPYRIGHT**

ETAL, P1200, P3189, and P3800 are Trade Marks of Profec Technologies Ltd.  
The Trade Mark ETAL is registered at the UK Trade Marks Registry.

Profec Technologies Ltd. is the owner of the design right under the Copyright Designs and Patents Act 1988 and no rights or licences are hereby granted or implied to any third party.

P3189 design and construction are protected by patents and registered design.  
British Patent No. 2340667.  
UK Registered Design No. 2077360.  
French Registered Design No. 991512.  
Germany Registered Design 49902311.0.  
United States Registered Design 426, 815.  
Other patents and registered designs pending.

© 1998 - 2000 Profec Technologies Ltd.  
Reproduction prohibited.

Patented

**PROFEC**  
TRANSFORMING THE FUTURE



ISO 9001  
FM 25326

Profec Technologies Ltd., 10 Betts Avenue, Martlesham Heath, Ipswich, IP5 3RH, England  
Telephone: +44 (0) 1473 611422 Fax: +44 (0) 1473 611919  
Websites: www.etal.ltd.uk www.profec.com  
Email: info@etal.ltd.uk sales@profec.com